



www.cmrelectrical.com

# LD2-3 & LD2-3V One & Two Zone Water Detection Alarm Installation and Operation Manual



# Contents

- 1) **Display and Control**
- 2) **Operation**
- 3) **Water Leak Detection Alarm Test**
- 4) **Water Detected Alarm**
- 5) **Display Screens**
- 6) **Sensor Fault**
- 7) **Water Detection Sensitivity Adjustment**
- 8) **Installation**
- 9) **Positioning the Water Detection Cable**
- 10) **Fitting Cable Clips**
- 11) **Mounting a Spot Probe**
- 12) **Water Shutdown Valve**
- 13) **Water Shutdown Valve Override Procedure**
- 14) **Beacon and Beacon Sounder**
- 15) **Fitting an SCA Repeat Alarm or SMS / Email Messaging System**
- 16) **Fitting the Battery Backup**
- 17) **Commissioning**
- 18) **Fault Diagnostics**
- 19) **Maintenance**
- 20) **Installation Drawing**

## 1) Display and Control

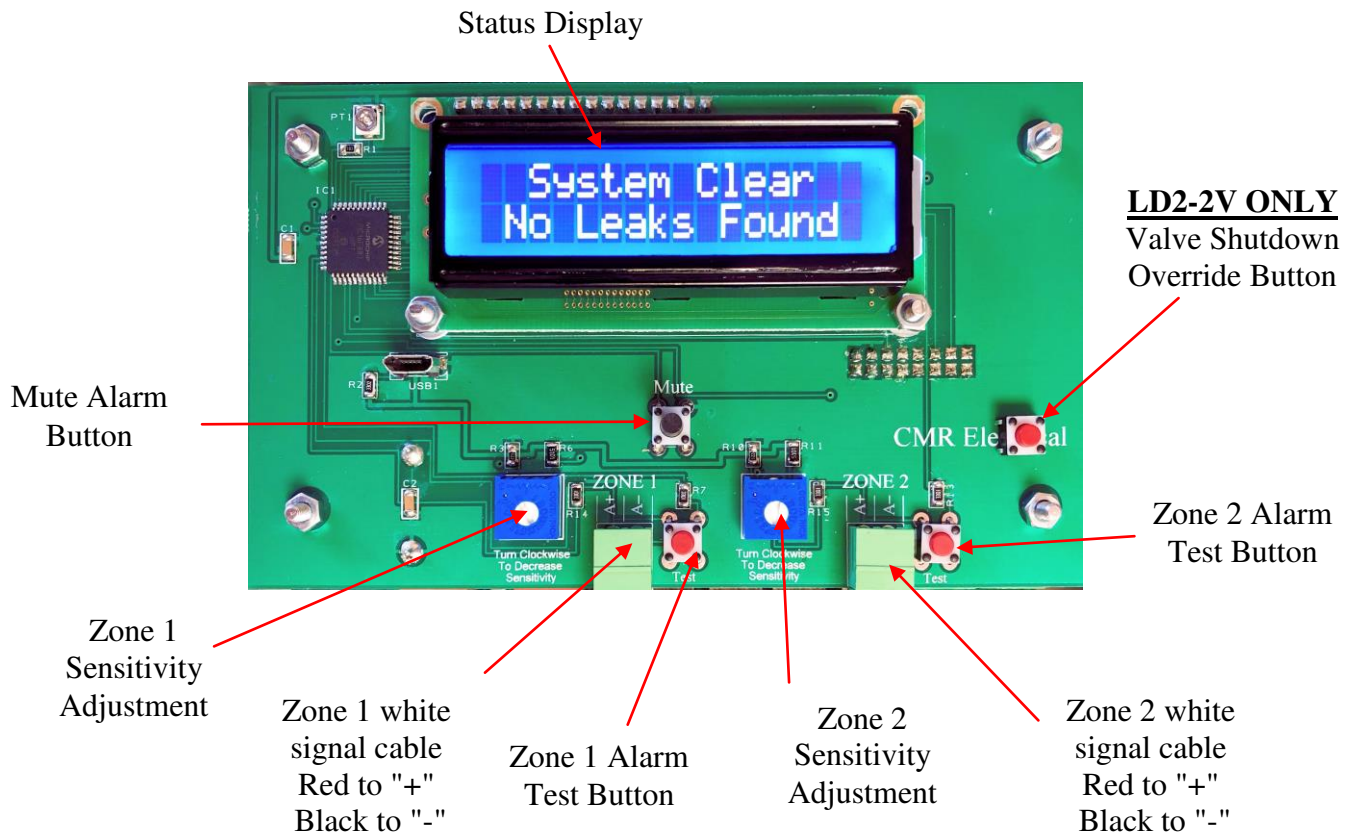

## 2) Operation

In normal operation with no alarms or faults, the audible warning device will be OFF and the display will be showing screen 1 (see below).

When one of the water sensors detects a leak, the audible warning will start pulsing, the display will show the zone in alarm (see screen 2 below), and if fitted, the following optional features will operate:

- Common alarm BMS contact
- Zone BMS relay
- Remote beacon or beacon sounder
- SMS system will send an Alarm message

The unit will remain in this mode until the “Mute” button has been pressed. Once muted, the audible warning will stop and if fitted, the remote sounder will stop.

Once the leak has been rectified and water removed from the sensor, the system will automatically reset to normal operation.

If a sensor becomes disconnected or damaged, the audible warning will sound, and the display will show the faulty zone (see screen 3 below). The unit will remain in this mode until the “Mute” button is pressed. Once the sensor fault has been rectified, the system will automatically revert to normal running provided the “mute” button has been operated.

## 3) Water leak Detection Alarm Test

To test that the unit is functioning correctly, press the red “Test Zone” button to simulate water being detected by the sensor and put the system into ‘water detected alarm’. This test alarm, like the normal alarm, will need muting. Using the test facility will operate the alarm relays, generating a BMS alarm. The LD2-3V systems will also close the water shutoff valves.

#### 4) Water Detected Alarm

When the detection cable comes into contact with water, the audible warning device will start, the alarm relay will close and the display will start flashing. To stop the audible warning, press the “Mute Alarm” button. On muting, the display will stop flashing and display the alarm location. The system will remain in this state until the water is removed from the cable.

#### 5) Display Screens

Screen 1

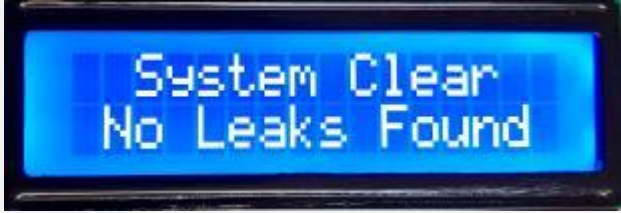

1 Zone unit  
No leaks have been detected



2 Zone unit  
No leaks have been detected

Screen 2



1 Zone unit  
New water leak found



2 Zone unit  
New water leak found on zone 1

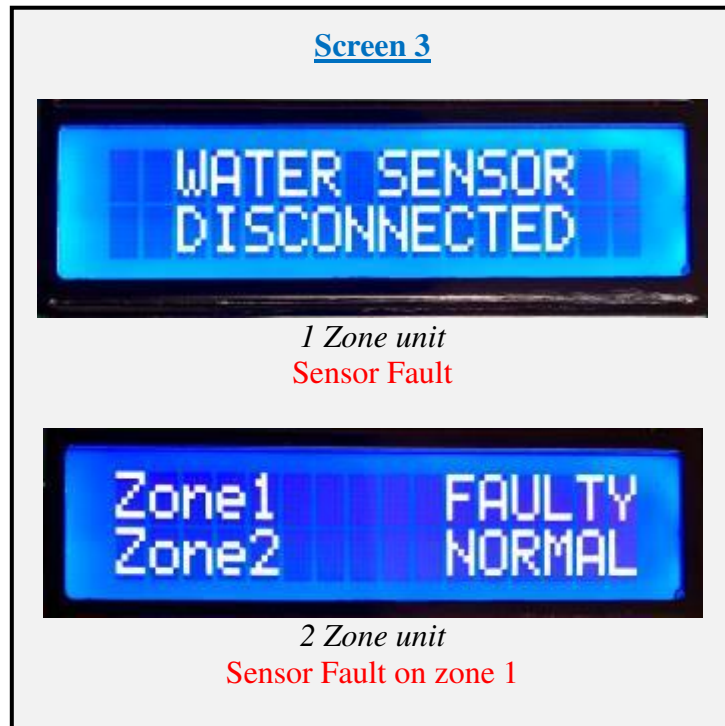

**6) Sensor Fault**

Due to the exposure of the detection cable on the floor, the system monitors for any breaks in the detection cable and the interconnection cable between the control unit and the detection cable. Provided continuity is maintained, the unit will display screen 1.

If a break within the cable is found, the audible warning device will start, the display will change to screen 3 and start flashing. To stop the audible warning, press the “Mute Alarm” button. On muting, the screen will stop flashing indicate an acknowledged alarm. The system will remain in this state until the cable fault is repaired. The display will then revert back to screen 1.

If the controller detects a break in the cable, the system will continue to detect water up to the point of the break.

**7) Water Detection Sensitivity Adjustment**

To increase the sensitivity of the cable, turn the potentiometer CLOCKWISE.

To de-crease the sensitivity turn ANTICLOCKWISE.



Increase Sensitivity



Decrease Sensitivity

**8) Installation**

**THIS EQUIPMENT SHOULD ONLY BE CONNECTED AND WORKED ON BY A QUALIFIED ELECTRICIAN.**

To mount the unit to a wall, first remove the front cover to expose the internal equipment. In each corner of the housing you will find the mounting holes.

Care should be taken when drilling to ensure no damage occurs to the electronic equipment inside.

A suitably rated 230VAC power cable supply should be run from a fused spur to the unit and terminated to the internal terminal block marked “L”, “E” & “N”. The fuse within the fused spur should be rated at 5 Amps.

**Connections within the Alarm Housing**

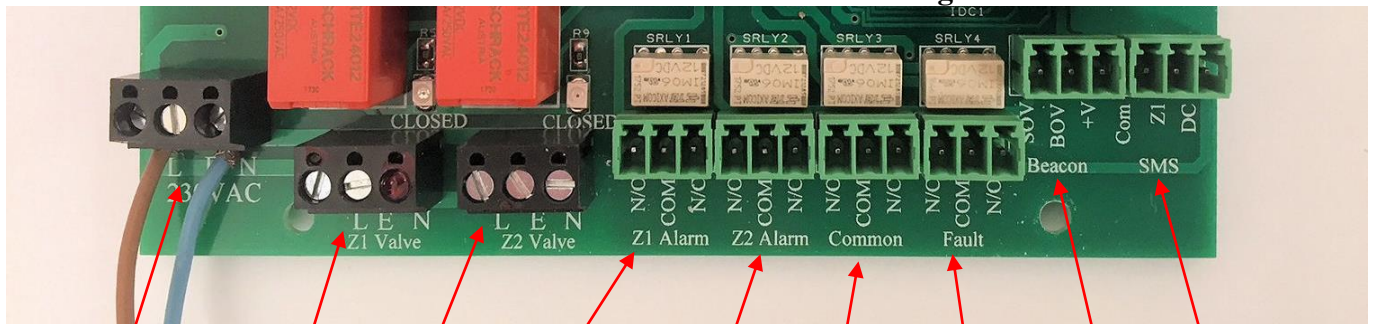

- Mains Input
- If Fitted**  
230VAC  
To Zone 1  
Shutdown  
Valve
- If Fitted**  
230VAC  
To Zone 2  
Shutdown  
Valve
- If Fitted**  
Zone 1  
Output  
Alarm  
Contact
- If Fitted**  
Zone 2  
Output  
Alarm  
Contact
- Common  
Alarm  
Output  
Alarm  
Contact
- Common  
Fault  
Output  
Alarm  
Contact
- If Fitted**  
Beacon/Sounder
- If Fitted**  
SMS Text

**Output Volt Free contacts for use by a Building Management System**

| Function Required             | Fitted as Standard | Relay Output Terminals |
|-------------------------------|--------------------|------------------------|
| Zone 1 alarm                  | No                 | Z1 Alarm               |
| Zone 2 alarm                  | No                 | Z2 Alarm               |
| Water detected alarm any zone | Yes                | Common Alarm           |
| Cable Disconnected Alarm      | Yes                | Common Fault           |
| Power Fault                   | Yes                | Common Fault           |

## Connection of the Signal cable, Water detection cable & End Of Line Terminator

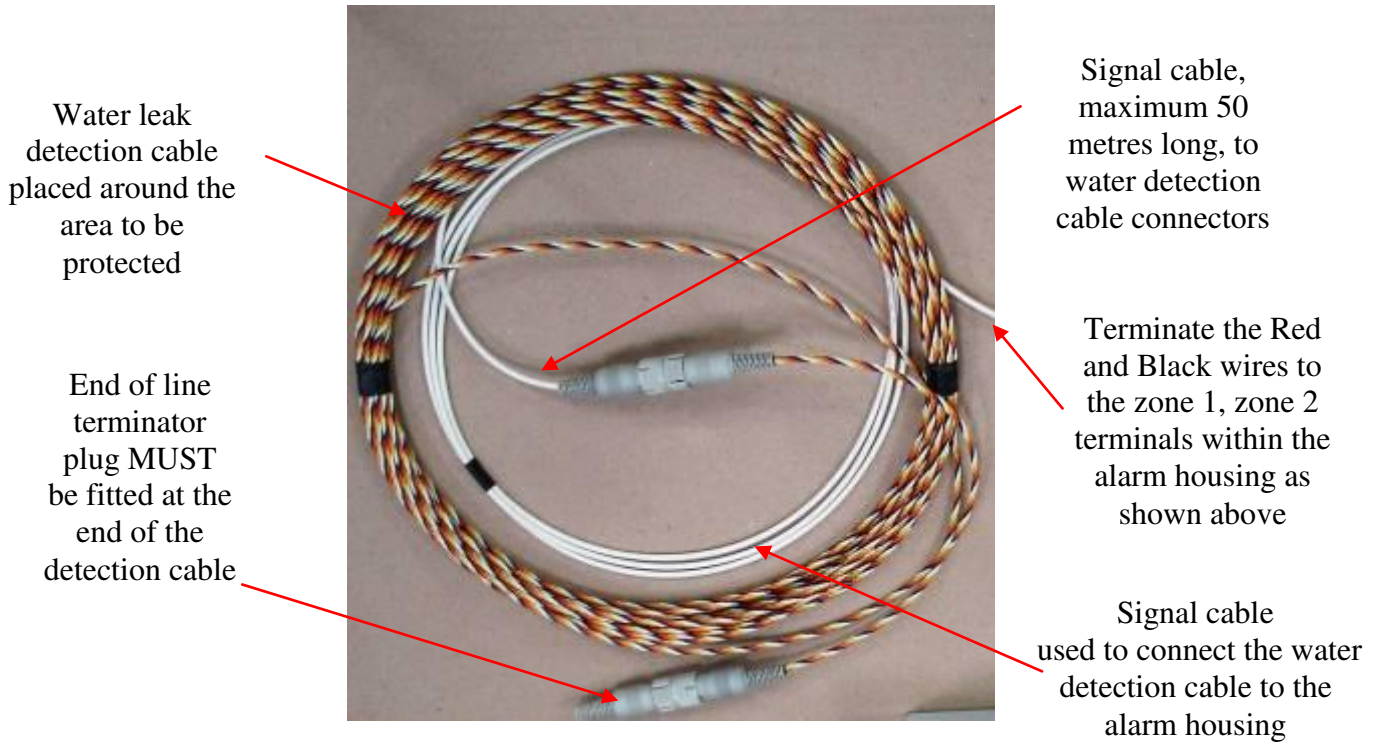

### **9) Positioning the Water Detection Cable**

The detection cable is susceptible to damage and should not be fitted to areas where the cable is likely to be damaged or walked on. If fitting the cable around Air Conditioning Units with humidifiers, ensure that cable is positioned at least one metre from the ACU to stop intermittent alarms being generated from over humidity or water droplets from the AHU. Having positioned the detection cable, ensure that the end of line terminator is plugged into the end of the cable (*see drawing above*).

### **10) Fitting Cable Clips**

If cable clips are required, to protect the small sensor wires and to stop false 'water detected alarms' from occurring, insulating tape should be first applied around the detection cable before the clip tongue is closed. Clips should be fitted approximately every 1 to 1.5 metres apart. When using clips make sure that the cable touches the floor between the clips, **DO NOT** tighten the cable so that the cable does not touch the floor.

Insulating tape to be used under the fixing clip tongue



### **11) Mounting a Spot Probe**

Spot probes are supplied with a mounting bracket that can be used to secure the sensor to a wall or the side of a large drip tray. In some applications the mounting bracket may not be required and can be discarded. Two 4.5mm countersunk holes are provided for fixing or the bracket can be glue fixed. When fixing, the stainless-steel pins should be touching the floor providing the flooring is nonconductive i.e., concrete, wood or plastic. For conductive areas, the stainless-steel probes **MUST NOT** touch the surface, they must be raised to provide a 0.5mm gap between floor and sensor.

Height adjustment is provided by sliding the sensor slightly out of its holder. The sensor can also be removed by sliding it out of its holder for testing, maintenance or when cleaning the floor.

For steel drip trays the sensor has been designed to be positioned on its back with the sensors either facing downward or upside down if a large amount of water is required before detection.

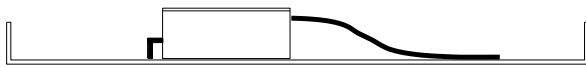

Drip tray without the mounting bracket

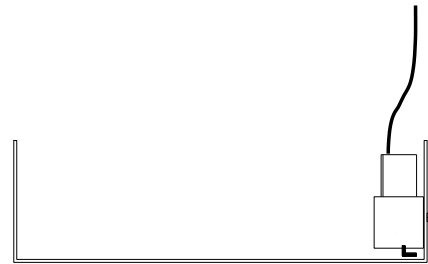

Deep drip tray side mounted using bracket  
(Sensor not to touch a conductive drip tray)

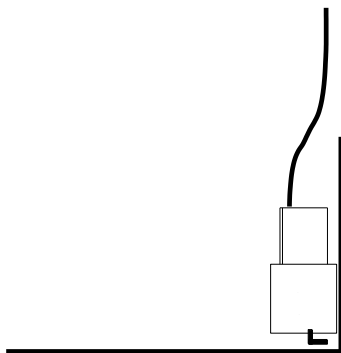

Mounting to a wall or structure  
(Sensor to touch floor unless floor is conductive)

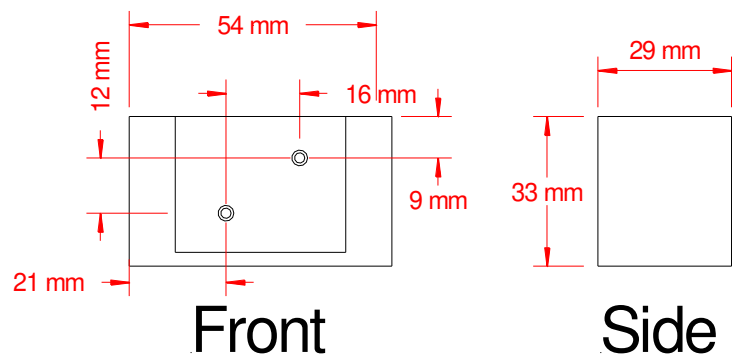

Mounting bracket fixing details

Once the sensor has been positioned, extend the white cable back to the alarm outstation using a 2-core cable, for example Belden 9502. Connect the two cables to the appropriate zone terminals using the removable green terminal block from the outstation. When making connections, ensure that the RED wire from the white cable is terminated to the zone terminal marked “Sig+” and the black cable to “Sig-“. Once both cables have been terminated, give a slight tug to each wire to ensure correct termination to the terminal block. Reversing the cabling will set the zone into “Alarm”, if this happens revert to the terminal connections.

## **12) Water Shutdown Valve**

If the system is supplied with water shutoff valves, once a water leak has been detected the unit will remove the 230V supply holding open the valve thereby closing it and stopping the flow of water. Once the leak has been rectified the detection cable may take some hours to dry out. During the dry out period the valve can be opened and closed using the procedure outlined in *Item 12* below.

### **Connection of Water Shutdown Ball Valve**

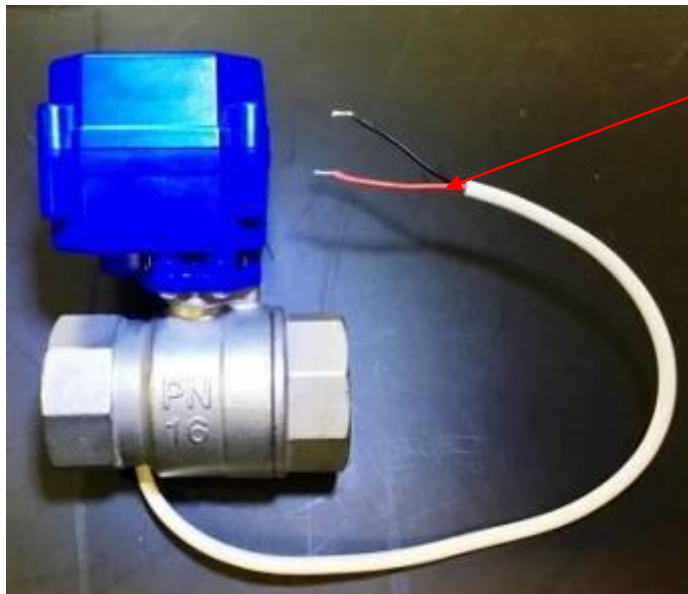

The 230VAC supply to the valves is generated from within the alarm unit. 15 to 25mm valves are supplied with a red and black cable, whilst larger valves are red and green. For good practice connect live to the red wire and neutral to the black or green wire.

The valve is supplied with a short length of cable that will need extending back to the Z1 or Z2 Valve terminals within the alarm unit.

**WARNING: In order to shut properly, this type of valve need powering for at least 3 minutes.**

### **Connection of Water Shutdown Solenoid Valve**



The 230VAC supply to the valves is generated from within the alarm unit.

Having removed and opened the 3 pin socket, connect live to terminal "1", neutral to terminal "2" and Earth to the earth terminal

#### **PLEASE NOTE;**

**The type of valve MUST be fitted with the arrow on its body facing the direction of flow, if not, the valve will not stop the flow of water.**

### **13) Water Shutdown Valve Override Procedure**

This feature will only work if there is a current ‘water leak detected’ alarm, and the alarm has been ‘Muted’. To put the system into shutdown override and re-open the valve, press and keep pressed the ‘Override’ push button. On pressing the button, the unit will start beeping. Keep your finger on the button and wait until the beeping stops. Once this happens, stop pressing the Mute button. The system will automatically cancel the override once the zone stops detecting water.

If override needs cancelling and the valve needs closing again, press the ‘Mute’ button and follow the same procedure to cancel the override and close the shutdown valve.

### **14) Beacon and Beacon Sounder**

If a beacon or beacon sounder is supplied, connect to the three terminals identified as ‘Beacon Sounder’ as follows.

#### **14a) Non Mutable Beacon or Beacon Sounder**

If the beacon or the beacon sounder is to be active (on all the time) until the water leak alarm has cleared, connect as follows:

| <b>Terminal Reference</b> | <b>Connect Beacon / Beacon Sounder terminals to the following terminals</b> |
|---------------------------|---|
| +V                        | Beacon +V or Strobe /Tone + terminal  |
| BOV                       | Beacon -V or Strobe /Tone - terminal  |
| SOV                       | NO connection to this terminal  |

#### **14b) Mutable Beacon or Beacon Sounder**

If the beacon or the beacon sounder is to turn off when the ‘Mute’ push button is pressed, connect as follows:

| <b>Terminal Reference</b> | <b>Connect Beacon / Beacon Sounder terminals to the following terminals</b> |
|---------------------------|---|
| +V                        | Beacon +V or Strobe /Tone + terminal  |
| BOV                       | NO connection to this terminal  |
| SOV                       | Beacon -V or Strobe /Tone - terminal  |

#### **14c) Mutable Sounder Beacon on all the time**

If the beacon is to remain alight all the time an alarm is current but the sounder is to be turned off when the ‘Mute’ push button is pressed, connect as follows:

| <b>Terminal Reference</b> | <b>Connect Beacon / Beacon Sounder terminals to the following terminals</b> |
|---------------------------|---|
| +V                        | Strobe and Tone + terminal  |
| BOV                       | Strobe - terminal   |
| SOV                       | Tone - terminal   |

**Warning; if the above option ‘14c’ is required, remove the electrical link connected between the second (Strobe -) & third terminals (Tone -) terminals within the sounder.**

## 15) Fitting an SCA Repeat Alarm or SMS / Email Messaging System

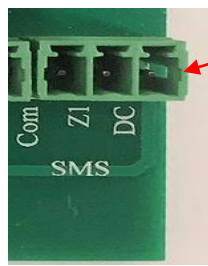

Use the “SMS” terminal block

| SCA Terminal No. | SMS Terminal No. | Cable wire colours fitted to the messaging system |
|------------------|------------------|---|
| +V               | DC               | <b>RED</b>  |
| Sig.             | Z1               | <b>BLUE</b>                                       |
| 0V               | COM              | <b>BLACK</b>                                      |

## 16) Fitting the Battery Backup

If supplied, the battery box should be fitted and connected to the alarm unit after the system has been commissioned. Connect the BLACK cable to the “—” battery terminal and the RED cable to the battery “+” terminal. If the battery is misconnected, the battery fuse located on the bottom PCB will blow.

## 17) Commissioning

- Once the unit has been connected as described above, turn on the mains power to the unit. The screen should display screen 1 (*item 5 above*), *If not, refer to the “Fault Diagnostics” below*. If the unit powers up with the audible warning active, press the mute button and wait to see if the alarm clears. *If the alarm remains after approximately 20 seconds, refer to the “Fault Diagnostics” below*.
- With the unit powered, unplug the end of line terminator positioned at the end of the detection cable. The controller should display screen 3 (*item 5 above*) and the audible warning device should sound, *if not, refer to the “Fault Diagnostics” below*.
- Press the “Mute” button, the audible warning device should stop. Replace the end of line terminator to return the system to normal and repeat for the other zone.
- Using a cup of CLEAN water, immerse a small area (50mm long) of cable into the water. The controller should display screen 2 (*item 5 above*) and the audible warning device should sound, *if not refer to the “Fault Diagnostics” below*.
- Press the “Mute” button, the audible warning device should stop. Remove from the water and wipe the cable with some tissue paper.
- Repeat for all other zones.

## **18) Fault Diagnostics**

| <b>Fault</b>  |  | <b>Possible Reason</b>  |
|---|--|---|
| Display is OFF and the unit appears dead  |  | 1) No power to the control unit. <i>Test with a meter</i><br>2) The power fuse has blown. <i>Test the fuse with a meter</i>   |
| The Water Detected statement remains on the screen all the time.  |  | 1) The cable needs drying out after detecting water. <i>Using tissue paper dry the cable.</i><br>2) The cable has a short between the sensors due to contaminants. <i>Clean the cable using water and tissue paper dry out afterwards</i><br>3) The cable has been damaged. <i>Visually check the cable for damage.</i><br>4) The sensitivity of the detection system is too sensitive. <i>Remove the lid from the small plastic box connected to the detection cable and turn the potentiometer until the system resets.</i><br>5) System fault. <i>Return to manufacturer</i> |
| The display appears dead and does not show “Water Detected” even though the system has a water detected alarm and the audible warning device is sounding. |  | 1) System fault. <i>Return to manufacturer</i>  |
| The system will not record a water detected alarm, the Display and audible warning device do not react to water on the cable.                             |  | 1) Sensitivity could be too low or a possible system fault. <i>Remove the lid from the small plastic box connected to the detection cable and turn the potentiometer until the system goes into alarm.</i><br>2) System fault. <i>Return to manufacturer</i>  |
| The display shows faulty or disconnected cable all the time.  |  | 1) The detection or signal cable is broken or disconnected. <i>Check for cable faults or breaks.</i><br>2) Detection module fault. <i>Dip part of the detection cable into a cup of water and see if it sets up an alarm.</i><br>3) Controller fault. <i>Press the test button to setup an alarm.</i><br>4) System fault. <i>Return to manufacturer</i>   |
| Horn not working  |  | 1) System fault. <i>Return to manufacturer</i>  |
| The battery will not power the system   |  | 1) Battery discharged, disconnect a lead and test with meter.<br>2) Battery fuse blow, see item 10<br>3) Charger fault, disconnect a battery lead & check for 13.5V   |

## **19) Maintenance**

The system should be fully tested at least one a year for correct operation and a check made to ensure that the shutoff valve operates correctly. All cables should be inspected at the same time for signs of damage, dirt contamination or mis-placement.

## 20) Installation Drawings

System using Water Detection Cable. Not all the shown devices may be available on your system

