



www.cmrelectrical.com

1 and 2 Zone Room Over Temperature and Humidity Alarm Installation and Operation Manual



Contents

- 1) **Display and Control**
- 2) **Operation**
- 3) **Display Screens**
- 4) **Positioning the Temperature Sensor**
- 5) **Sensor Wiring**
- 6) **Setting the Alarm Trip Setpoint**
- 7) **Power, BMS, Beacon and SMS Connections**
- 8) **Beacon and Beacon Sounder**
- 9) **Fitting an SMS / Email Messaging System**
- 10) **Commissioning**
- 11) **Installation Drawings**

1) Display and Control

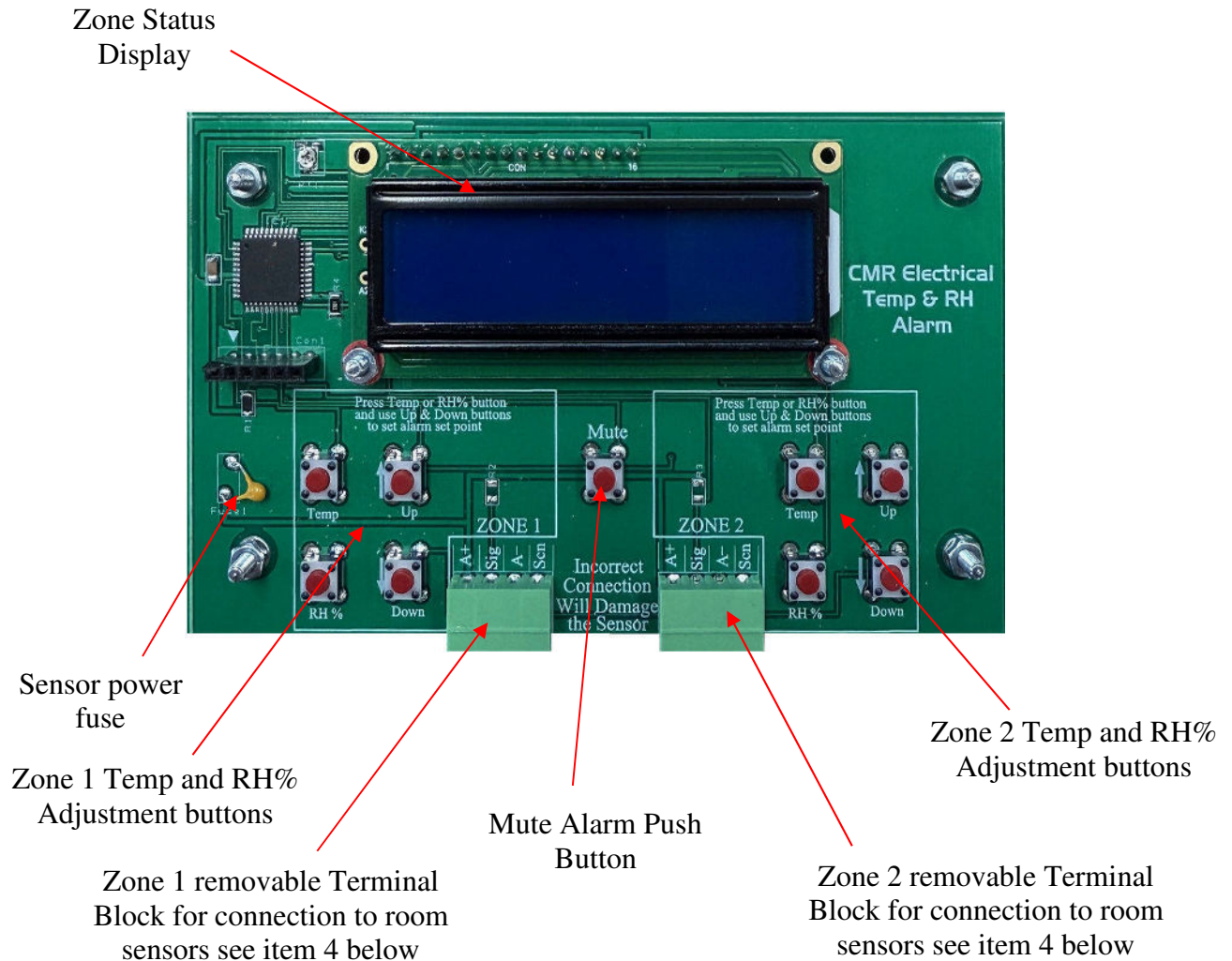

2) Operation

When powered on, the unit briefly displays Screen 1 (see photos below on Page 4). If there are no alarms or faults, the audible warning device will remain OFF, and the display will transition to Screen 2. For units with two zones, the display alternates between Zone 1 and Zone 2. Alarm trip points (setpoints) can be adjusted using the four red buttons on the top board: the left side adjusts Zone 1, and the right side adjusts Zone 2 (refer to “Setting the Alarm Trip Setpoints”).

When ambient temperature or humidity exceeds the alarm setpoint, the system triggers an audible warning, displays the zone in alarm (Screen 3 or Screen 5), and activates the common alarm BMS contact. Optional features, such as the zone BMS relay, remote beacon/beacon sounder, and SMS alarm notifications, will also activate if configured.

The unit will remain in alarm mode until the "Mute" button is pressed. This silences the audible warning, stops the remote sounder (if fitted), and updates the display to Screen 4 or Screen 6. Once the temperature drops below the setpoint by 2°C or 5% RH, the system resets to normal operation automatically.

If a sensor is disconnected or damaged, the system will sound an audible warning, activate the common alarm relay, and display the faulty zone (Screen 7). This mode persists until the “Mute” button is pressed. After the sensor fault is resolved, the system will automatically return to normal operation once the “Mute” button is pressed.

In case of a sensor power fuse trip, the unit will sound an alarm and display Screen 8. The fuse will reset once the short between terminals A+ and A- has been removed. The system will resume normal operation once the fault is cleared and the “Mute” button is pressed.

3) Display Screens

The following applies for both Zone 1 and Zone 2



Screen 1 - The unit will display this for a few seconds after powering up



Screen 2 - Normal screen no alarms showing temperature & humidity



Screen 3 - New unmuted one zone over temperature alarm



Screen 4 - Over Temperature alarm after Muting



Screen 5 - New unmuted one zone over Humidity alarm



Screen 6 - Over Humidity alarm after Muting



Screen 7 - The sensor on zone 1 has become disconnected or is faulty

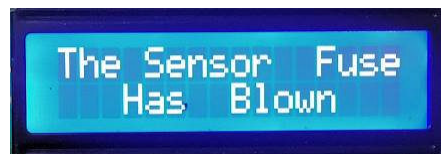

Screen 8 - The sensor power fuse has blown

4) Positioning the Temperature Sensor

Proper positioning of the sensor is crucial for accurate temperature monitoring. Keep in mind that hot air rises and forms localized "hot spots." For example, one corner of a room may be 21°C, while another corner near a heat source could reach 25°C. Similarly, placing the sensor one meter above the floor, when the primary heat source is at a height of two meters, could result in inaccurate readings and potential damage to sensitive equipment.

To ensure reliable measurements, mount the sensor in the area most likely to experience the highest temperatures. For instance, in a room with a 2-meter-high server rack, position the sensor at a height of approximately 2 to 2.5 meters on a wall or column adjacent to the racks.

If the exact location or type of heat source is unknown during installation, place the sensor at a height between 1.8 and 2.5 meters (depending on room height), preferably in the centre of the room, to provide the most balanced coverage.

5) Sensor Wiring

Using the pluggable 4-way terminals (*as shown in Item 1 above*), connect the sensor to the alarm unit as follows, using a 4 core 0.22mm screened cable such as RS 8124725. The sensor cable should not exceed 50m in length, and should not be run in parallel to, or near, any power cables, bus-bars or any source of electrical or radio interference.

Alarm Unit Terminal Reference	Cable Colour	Sensor Terminal Reference
A+	Red	A+
Sig	White	Sig
A-	Black	A-
Scn	Screen	No connection

Do NOT connect the screen to any terminal or earth at the sensor box end

6) Setting the Alarm Trip Setpoint

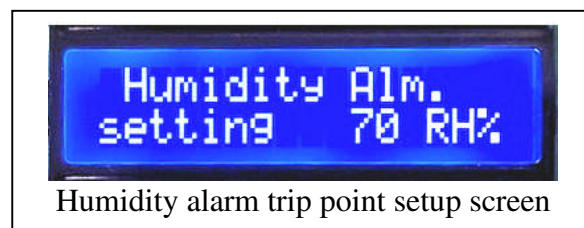

Each zone is equipped with four buttons for adjusting the alarm trip points for temperature (0–50°C) and humidity (0–90% RH).

To set the temperature alarm trip point:

1. Press and hold the “Temp” button for Zone 1 or Zone 2. The corresponding screen will appear.
2. Use the “Up” or “Down” buttons to adjust the value until the desired temperature is displayed.
3. Release all buttons when finished.

To set the humidity alarm trip point:

1. Press and hold the “RH%” button for Zone 1 or Zone 2. The corresponding screen will appear.
2. Adjust the value using the “Up” or “Down” buttons.
3. Release all buttons when done.

To verify the new setpoint, press the “Temp” or “RH%” button again. For systems with two zones, follow the same procedure using the Zone 2 buttons on the right-hand side.

The alarm trip points are stored in non-volatile memory, so adjustments are only necessary when a new setpoint is required.

Note: The unit is factory set to 25°C and 60% RH for both Zone 1 and Zone 2.

7) Power, BMS, Beacon and SMS Connections

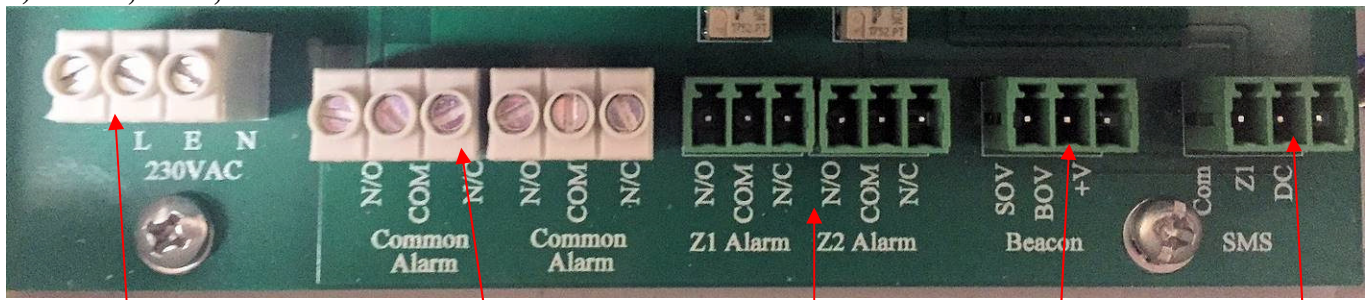

90 to 265VAC
Input power

2 x common alarm and
power fault volt free
BMS contacts

Optional feature:
Individual zone
alarm contacts to
BMS

Optional feature:
12VDC output
to Beacon or
Beacon Sounder

Optional feature:
Output to
SMS

Output Volt Free contacts for use by a Building Management System

Function Required	Fitted as Standard	Relay Output Terminals
Zone 1 alarm	No	Z1 Alarm
Zone 2 alarm	No	Z2 Alarm
Over temp/RH% alarm contact 1 any zone & power fault	Yes	Common Alarm & power fault
Over temp/RH% alarm contact 2 any zone & power fault	Yes	Common Alarm & power fault

The Common alarm relay is normally energised, de-energised in alarm or power fault, therefore both “Common Alarm” contacts are identified correctly when the unit is powered and has no current alarms.

BMS relays do not operate for blown fuse or sensor fault

8) Beacon and Beacon Sounder

If a beacon or beacon sounder is supplied, connect to the three terminals identified as “Beacon” as follows:

8a) Non-Mutable Beacon or Beacon Sounder

If the beacon or the beacon sounder is to be active (on all the time) until the water leak alarm has cleared, connect as follows:

Terminal Reference	Connect Beacon / Beacon Sounder terminals to the following terminals
+V	Beacon +V or Strobe /Tone + terminal
BOV	Beacon -V or Strobe /Tone - terminal
SOV	NO connection to this terminal

8b) Mutable Beacon or Beacon Sounder

If the beacon or the beacon sounder is to turn off when the “Mute” push button is pressed, connect as follows:

Terminal Reference	Connect Beacon / Beacon Sounder terminals to the following terminals
+V	Beacon +V or Strobe /Tone + terminal
BOV	NO connection to this terminal
SOV	Beacon -V or Strobe /Tone - terminal

8c) Mutable Sounder Beacon on all the time

If the beacon is to remain alight all the time an alarm is current but the sounder is to be turned off when the “Mute” push button is pressed, connect as follows:

Terminal Reference		Connect Beacon / Beacon Sounder terminals to the following terminals
+V		Strobe and Tone + terminal
BOV		Strobe - terminal
SOV		Tone - terminal

Warning: if the above option “8c” is required, **remove** the electrical link connected between the second (Strobe -) & third terminals (Tone -) terminals within the sounder.

9) Fitting an SMS / Email Messaging System

If an SMS text messaging or Email messaging unit is supplied, connect it as follows to the 3 way terminal block identified as “SMS”:

Terminal Reference		Cable Wire Colours Fitted to the Messaging System
Z1		BLUE
COM		BLACK
DC		RED

10) Commissioning

After connecting the unit as described, switch on the mains power. The display will light up, showing Screen 1, and after a few seconds, it will transition to Screen 2. Note the current ambient temperature, then press and hold the internal red Zone 1 “Temp” button. This will bring up Screen 1 as referenced in item 6.

While holding the “Zone 1” button, press and release the “Down” button repeatedly until the displayed temperature is lower than the noted ambient temperature. Release both buttons. At this point:

- The audible warning will activate.
- Screen 3 will appear on the display.
- The “common alarm” contact will change state.
- If configured, the following optional features will also activate:
 - The beacon or beacon sounder.
 - The “Zone 1 Alarm” relay.
 - The SMS messaging system.

Press the “Mute” button to silence the audible warning and stop the remote beacon sounder (if fitted). The display will change to Screen 4.

To clear the alarm and set the high-temperature alarm trip point:

1. Press the “Zone 1” button again.
2. Use the “Up” button to adjust the setpoint to the desired temperature.
3. Ensure the display returns to Screen 2.

Repeat the above procedure for humidity using the “RH%” button. If the unit has two zones, follow the same steps using the Zone 2 buttons located on the right-hand side.

11) Installation Drawings

Not all the shown devices may be available on your system

